



**TEST REPORT**

Rendered to:

**USA VINYL, LLC**

For:

**6 ft by 8 ft with Interlocking Pickets and 6 ft by 8 ft with Lattice  
PVC Privacy Fence Assemblies**

**Report No: F9860.01-119-16**

**Test Date: 06/29/16**

**Report Date: 08/09/16**

**Test Record Retention Date: 06/29/20**



## **TEST REPORT**

Rendered to:

USA VINYL, LLC  
5795 Green Pointe Drive S  
Groveport, Ohio 43125

Report No.: F9860.01-119-16

Test Date: 06/29/16

Report Date: 08/09/16

Test Record Retention Date: 06/29/20

### **1.0 General Information**

#### **1.1 Product**

6 ft by 8 ft with Interlocking Pickets and 6 ft by 8 ft with Lattice PVC Privacy Fence Assemblies

#### **1.2 Project Description**

Architectural Testing, Inc., an Intertek company ("Intertek-ATI"), was contracted by USA Vinyl, LLC to perform dynamic wind load tests on their 6 ft by 8 ft with interlocking pickets and 6 ft by 8 ft with lattice PVC privacy fence assemblies. This report includes comprehensive written and photographic documentation of the testing performed.

## 2.0 Wind Load Testing

### 2.1 Test Specimen

One specimen (consisting of a 2-panel/3-post fully assembled fence section) of each vinyl privacy fence system was tested. Each panel measured approximately 6 ft tall by 8 ft wide. USA Vinyl, LLC provided all test materials to Intertek-ATI in York, Pennsylvania. See drawings in Appendix A for detailed descriptions of assembly and components.

### 2.2 Equipment

Two propeller fan wind generators were utilized for testing. The propeller of each fan was 84 in diameter and was comprised of four Kevlar composite airfoil units belt-driven by a high-output V8 engine. Wind speeds for the wind generators were calibrated according to AAMA 501.1-05. Deflections were measured with linear displacement transducers accurate to 0.01 inch.

### 2.3 Test Setup

A steel test fixture was designed and fabricated to simulate a rigid post embedment. The bottom of the bottom rail was fixed at two inches above the top of the test fixture. The wind generator outlet was located 4 ft from the face of the specimen (see photographs in Appendix B). Linear transducers were fixed on the top rail, middle of the in-fill area, and bottom rail for deflection measurements.

### 2.4 Test Procedure

Wind load testing began at 30 mph for specimen No. 1 and 50 mph for Specimen No's 2 through 3 and increased until failure or a maximum wind speed of 130 mph. Wind loads were performed with a relaxation period after 50 mph and 80 mph to record permanent set measurements. The duration of the applied wind load at each wind speed was determined by using the following equation:

$$t = 3600 / V_{fm} \quad (\text{Equation 1})$$

where:

$t$  = duration (s), required for a one mile long sample of air to pass

$V_{fm}$  = "fastest mile" wind speed (mph)

Wind speeds used in testing correlate with "fastest mile" wind speeds ( $V_{fm}$ ) for reference to codes and design standards. Maximum deflections were recorded at each load level.

## 2.5 Test Results

### Test Series No. 1

**Description:** 6 ft high by 8 ft wide (nominal) PVC privacy fence with interlocking pickets

**Top / Mid / Bottom Rail:** 5-1/2 in high by 1-1/2 in wide by 95-5/8 in long (0.090/0.060 in wall) PVC slotted rails with two locking tabs per side on each rail end.

**Rail Reinforcement:** 1-11/16 in high by 1-1/4 in wide by 95-11/16 in long by 0.64 in thick I-shaped extruded aluminum (bottom rail only)

**Panels:** Seven 7/8 in deep by 13-7/8 in wide by 31-1/4 in long by 0.060 in thick interlocking pickets per infill area (two areas per panel) each with two locking tabs per side on each panel end.

**Post:** Three 5 in by 5 in by 107-13/16 in long (0.150" wall) routed PVC posts

**Post Reinforcement:** 4-5/8 in high by 4-5/8 in wide by 53-13/16 in long by 0.11 in thick I-shaped extruded aluminum reinforcement with 1 in long returns on the flanges. Web was offset 1/4 in from center.

**Note:** *In lieu of aluminum reinforcement post can be filled with concrete to a height of 22 in above grade (54 in from bottom of post to top of concrete).*

**Rail Attachment:** Routed holes in the posts captured the ends of the rails. The locking tabs at the rail ends engaged the rails in the posts. Additionally, one #10-16 x 1" (0.138 in minor diameter) coated carbon steel pan head screw was installed in the top side of the top rail to prevent the rails from disengaging from the post.

**Panel Attachment:** Routed slots in the rails captured the ends of the panels. The locking tabs at the panel ends engaged the panels in the rails.

**2.5 Test Results (Continued)**

**Test Series No. 1  
(Continued)**

**Test Date: 06/29/16**

Wind Speed	Duration	Maximum Deflection (inches)					
		Top		Mid		Bottom	
		Left	Right	Left	Right	Left	Right
30 mph	120 sec	0.92	0.64	1.40	1.03	0.55	0.34
40 mph	90 sec	1.93	1.68	2.42	1.70	0.82	0.41
50 mph	72 sec	2.62	2.80	3.88	3.12	1.10	0.61
0 mph	Permanent Set	0.22	0.10	0.50	0.30	0.16	0.06
60 mph	60 sec	3.69	3.72	5.07	5.04	1.47	1.09
70 mph	51 sec	5.10	4.89	6.92	5.50	2.01	1.17
80 mph	45 sec	6.27	6.21	8.38	6.71	2.27	1.23
0 mph	Permanent Set	0.29	0.21	0.57	0.47	0.22	0.07
90 mph	40 sec	8.69	7.24	11.67	7.80	3.72	1.68
100 mph	36 sec	10.03	8.01	13.41	8.37	4.04	1.52
<b>Observation:</b> 3 seconds into the 110 mph velocity, the panels blew out							

Maximum Sustained Wind,  $V_{fm} = 100$  mph;  
 Equivalent 3-second gust,  $V_{3s} = 116$  mph;  
 Ultimate Design Wind Speed,  $V_{ult} = 150$  mph

## 2.5 Test Results: (Continued)

### Test Series No. 2

**Description:** 6 ft high by 8 ft wide (nominal) PVC privacy fence with interlocking pickets and with mechanical fasteners attaching the panels to the rails

**Top / Mid / Bottom Rail:** 5-1/2 in high by 1-1/2 in wide by 95-5/8 in long (0.090/0.060 in wall) PVC slotted rails with two locking tabs per side on each rail end.

**Rail Reinforcement:** 1-11/16 in high by 1-1/4 in wide by 95-11/16 in long by 0.64 in thick I-shaped extruded aluminum (bottom rail only)

**Panels:** Seven 7/8 in deep by 13-7/8 in wide by 31-1/4 in long by 0.060 in thick interlocking pickets per infill area (two areas per panel) each with two locking tabs per side on each panel end.

**Post:** Three 5 in by 5 in by 107-13/16 in long (0.150" wall) routed PVC posts

**Post Reinforcement:** 4-5/8 in high by 4-5/8 in wide by 53-13/16 in long by 0.11 in thick I-shaped extruded aluminum reinforcement with 1 in long returns on the flanges. Web was offset 1/4 in from center.

**Note:** *In lieu of aluminum reinforcement post can be filled with concrete to a height of 22 in above grade (54 in from bottom of post to top of concrete).*

**Rail Attachment:** Routed holes in the posts captured the ends of the rails. The locking tabs at the rail ends engaged the rails in the posts. Additionally, one #10-16 x 1" (0.138 in minor diameter) coated carbon steel pan head screw was installed in the top side of the top rail to prevent the rails from disengaging from the post.

**Panel Attachment:** Routed slots in the rails captured the ends of the panels. The locking tabs at the panel ends engaged the panels in the rails. Additionally, two #10-16 x 1" (0.138 in minor diameter) coated carbon steel pan head screws were installed at each panel end (one side only).

**Note:** *Panel attachment screws for both fence sections were located on the windward side of the test specimen.*

**2.5 Test Results:** (Continued)

**Test Series No. 2**  
(Continued)

**Test Date: 06/29/16**

Wind Speed	Duration	Maximum Deflection (inches)					
		Top		Mid		Bottom	
		Left	Right	Left	Right	Left	Right
50 mph	72 sec	2.70	2.45	3.21	3.11	1.16	0.93
0 mph	Permanent Set	0.09	0.02	0.07	0.09	0.07	0.08
60 mph	60 sec	3.71	3.31	4.16	4.10	1.62	1.04
70 mph	51 sec	5.36	4.92	5.88	5.25	2.41	1.89
80 mph	45 sec	7.60	6.04	7.22	5.83	2.99	1.90
0 mph	Permanent Set	0.34	0.21	0.51	0.30	0.21	0.05
90 mph	40 sec	9.31	7.69	8.53	7.92	4.12	2.48
100 mph	36 sec	11.73	9.33	10.50	7.60	5.09	2.68
115 mph	31 sec	13.14	9.67	11.89	9.77	6.11	3.04
120 mph	30 sec	15.02	9.73	17.39	17.39	12.68	3.70
<b>Observation:</b> 15 seconds into the 130 mph velocity, the panels blew out							

Maximum Sustained Wind,  $V_{fm} = 120$  mph;  
 Equivalent 3-second gust,  $V_{3s} = 137$  mph;  
 Ultimate Design Wind Speed,  $V_{ult} = 177$  mph

## 2.5 Test Results: (Continued)

### Test Series No. 3

**Description:** 6 ft high by 8 ft wide (nominal) PVC privacy fence with lattice

**Top Rail:** 3-1/2 in high by 1-3/4 in wide by 95-3/4 in long (0.110 in wall) PVC slotted rails with one locking tab per side on each rail end.

**Bottom / Mid Rail:** 5-1/2 in high by 1-1/2 in wide by 95-5/8 in long (0.090/0.060 in wall) PVC slotted rails with two locking tabs per side on each rail end.

**Rail Reinforcement:** 1-11/16 in high by 1-1/4 in wide by 95-11/16 in long by 0.64 in thick I-shaped extruded aluminum (bottom rail only)

**Panels:** - Seven 7/8 in deep by 13-7/8 in wide by 52 in long by 0.060 in thick interlocking pickets with two locking tabs per side on each end.

- One 12 in high by 91 in long by 0.180 in thick lattice panel.

**Lattice End Cap:** 1-1/2 in high by 7/8 in deep by 9 in long by 0.70 in thick slotted PVC channel (one at each end of lattice panel).

**Post:** Three 5 in by 5 in by 107-13/16 in long (0.150" wall) routed PVC posts

**Post Reinforcement:** 4-5/8 in high by 4-5/8 in wide by 53-13/16 in long by 0.11 in thick I-shaped extruded aluminum reinforcement with 1 in long returns on the flanges. Web was offset 1/4 in from center.

**Note:** *In lieu of aluminum reinforcement post can be filled with concrete to a height of 22 in above grade (54 in from bottom of post to top of concrete).*

**Rail Attachment:** Routed holes in the posts captured the ends of the rails. The locking tabs at the rail ends engaged the rails in the posts. Additionally, one #10-16 x 1" (0.138 in minor diameter) coated carbon steel pan head screw was installed in the top side of the top rail to prevent the rails from disengaging from the post.

**Panel Attachment:** - Interlocking Panels: Routed slots in the rails captured the ends of the panels. The locking tabs at the panel ends engaged the panels in the rails.

- Lattice Panel: Routed slots in the rails captured the top and bottom edges of the lattice panels.



**2.5 Test Results:** (Continued)

**Test Series No. 3**  
(Continued)

**Test Date: 06/29/16**

Wind Speed	Duration	Maximum Deflection (inches)					
		Top		Mid		Bottom	
		Left	Right	Left	Right	Left	Right
50 mph	72 sec	2.75	2.71	3.15	3.13	1.51	1.30
0 mph	Permanent Set	0.10	0.12	0.17	0.15	0.06	0.03
60 mph	60 sec	3.93	3.77	4.58	4.50	2.03	1.84
70 mph	51 sec	4.73	4.77	6.03	5.39	2.89	2.25
<i>Observation: Top lattice blew out during the 80 mph velocity</i>							

Maximum Sustained Wind,  $V_{fm} = 70$  mph  
 Equivalent 3-second gust,  $V_{3s} = 84$  mph;  
 Ultimate Design Wind Speed,  $V_{ult} = 108$  mph

## 2.5 Test Results: (Continued)

### Test Series No. 4

**Description:** 6 ft high by 8 ft wide (nominal) PVC privacy fence with lattice and with mechanical fasteners attaching the interlocking panels and lattice to the rails

**Top Rail:** 3-1/2 in high by 1-3/4 in wide by 95-3/4 in long (0.110 in wall) PVC slotted rails with one locking tab per side on each rail end.

**Bottom / Mid Rail:** 5-1/2 in high by 1-1/2 in wide by 95-5/8 in long (0.090/0.060 in wall) PVC slotted rails with two locking tabs per side on each rail end.

**Rail Reinforcement:** 1-11/16 in high by 1-1/4 in wide by 95-11/16 in long by 0.64 in thick I-shaped extruded aluminum (bottom rail only)

**Panels:** - Seven 7/8 in deep by 13-7/8 in wide by 52 in long by 0.060 in thick interlocking pickets with two locking tabs per side on each end.

- One 12 in high by 91 in long by 0.180 in thick lattice panel.

**Lattice End Cap:** 1-1/2 in high by 7/8 in deep by 9 in long by 0.70 in thick slotted PVC channel (one at each end of lattice panel).

**Post:** Three 5 in by 5 in by 107-13/16 in long (0.150" wall) routed PVC posts

**Post Reinforcement:** 4-5/8 in high by 4-5/8 in wide by 53-13/16 in long by 0.11 in thick I-shaped extruded aluminum reinforcement with 1 in long returns on the flanges. Web was offset 1/4 in from center.

**Note:** *In lieu of aluminum reinforcement post can be filled with concrete to a height of 22 in above grade (54 in from bottom of post to top of concrete).*

**Rail Attachment:** Routed holes in the posts captured the ends of the rails. The locking tabs at the rail ends engaged the rails in the posts. Additionally, one #10-16 x 1" (0.138 in minor diameter) coated carbon steel pan head screw was installed in the top side of the top rail to prevent the rails from disengaging from the post.

## 2.5 Test Results: (Continued)

### Test Series No. 4 (Continued)

#### Panel Attachment:

- Interlocking Panels: Routed slots in the rails captured the ends of the panels. The locking tabs at the panel ends engaged the panels in the rails. Additionally, two #10-16 x 1" (0.138 in minor diameter) coated carbon steel pan head screws were installed at each panel end (one side only).
- Lattice Panel: Routed slots in the rails captured the top and bottom edges of the lattice panels. Additionally, three #10-16 x 1-1/2" (0.138 in minor diameter) coated carbon steel pan head screws (11 in from each rail end and at rail midpoint) were installed along the top and bottom edges to attach the lattice panel to the top and mid rails (one side only) and two #10-16 x 1" (0.138 in minor diameter) coated carbon steel pan head screws were installed at each end to attach the lattice panel to the lattice end cap (one side only).

*Note: Panel and lattice attachment screws for each fence section were located on opposite sides (one section windward, one section leeward).*

**2.5 Test Results:** (Continued)

**Test Series No. 4**  
(Continued)

**Test Date: 06/29/16**

Wind Speed	Duration	Maximum Deflection (inches)					
		Top		Mid		Bottom	
		Left	Right	Left	Right	Left	Right
50 mph	72 sec	2.69	2.91	3.26	3.42	1.61	1.53
0 mph	Permanent Set	0.12	0.03	0.16	0.06	0.10	0.02
60 mph	60 sec	3.48	3.65	3.90	4.40	2.03	1.74
70 mph	51 sec	5.06	4.57	5.87	4.98	3.02	2.14
80 mph	45 sec	6.02	5.51	6.79	6.18	3.71	2.53
0 mph	Permanent Set	0.12	0.15	0.35	0.24	0.19	0.08
90 mph	40 sec	7.74	6.93	8.65	7.67	5.83	3.58
100 mph	36 sec	8.42	--	12.26	8.49	6.08	4.02
115 mph	31 sec	18.54	--	12.40	12.09	8.06	6.13
<b>Observation:</b> Center post buckled and panels blew out following the 31 second hold at 115 mph							

Maximum Sustained Wind,  $V_{fm} = 115$  mph;  
 Equivalent 3-second gust,  $V_{3s} = 131$  mph;  
 Ultimate Design Wind Speed,  $V_{ult} = 169$  mph

### 3.0 Closing Statement

Intertek-ATI will service this report for the entire test record retention period, a period of four years from the original test date. Test records that are retained such as detailed drawings, datasheets, representative samples of test specimens, or other pertinent project documentation will be retained by Intertek-ATI for the entire test record retention period.

Results obtained are tested values and were secured using the designated test methods. This report does not constitute certification of this product nor an opinion or endorsement by this laboratory. It is the exclusive property of the client so named herein and relates only to the specimens tested. This report may not be reproduced, except in full, without the written approval of Intertek-ATI.

For INTERTEK-ATI:

---

Isaiah W. Gebhart  
Technician II

---

V. Thomas Mickley, Jr., P.E.  
Senior Project Engineer

IWG:vtm/jas

Attachments (pages): This report is complete only when all attachments listed are included.

Appendix A - Drawings (9)

Appendix B - Photographs (4)

### Revision Log

<u>Rev. #</u>	<u>Date</u>	<u>Page(s)</u>	<u>Revision(s)</u>
0	08/09/16	N/A	Original report issue



F9860.01-119-16

## **APPENDIX A**

### **Drawings**

# PANEL PRIVACY 6'X8' w/ Interlocking Pickets

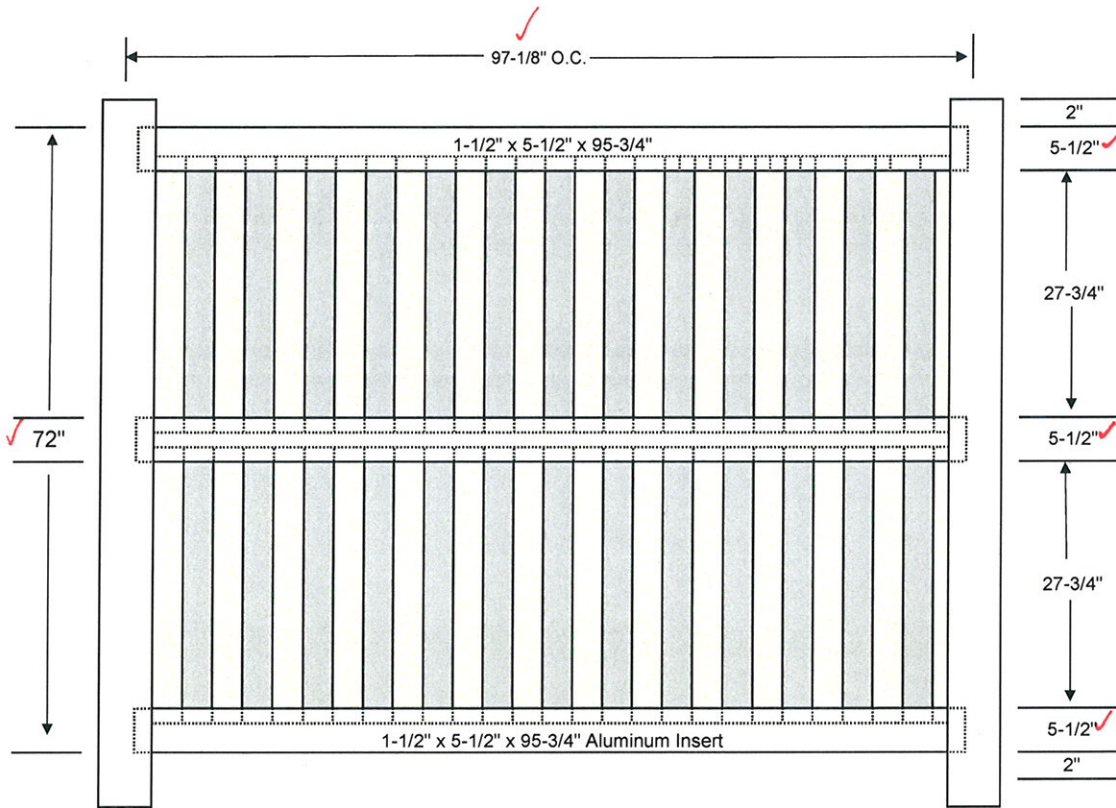

1

Material List			
Qty	Item	Dimensions	WRHS USE ONLY
1	Top Rail	1-1/2" x 5-1/2" x 95-3/4"	1-1/2" x 5-1/2" x 8' Rail
1	Middle Rail	1-1/2" x 5-1/2" x 95-3/4"	1-1/2" x 5-1/2" x 8' Rail
1	Bottom Rail	1-1/2" x 5-1/2" x 95-3/4"	1-1/2" x 5-1/2" x 8' Rail
1	Aluminum Rail Insert	1-1/4" x 1-3/4" x 95-3/4"	1-1/4" x 1-3/4" x 8' Aluminum Rail Insert
14	Pickets	7/8" x 13-7/8" x 31-1/4"	7/8" X 13-7/8" X 160" Panel Privacy Picket

\*Actual measurements may vary slightly.



Test sample complies with these details.  
Deviations are noted.

Report # F9860.01-119-16

Date 7-28-16 Tech T. MICKLEI

PWPR-PANELAH-6X8



PANEL PRIVACY 6'X8' w/ Lattice ACTUAL HEIGHT

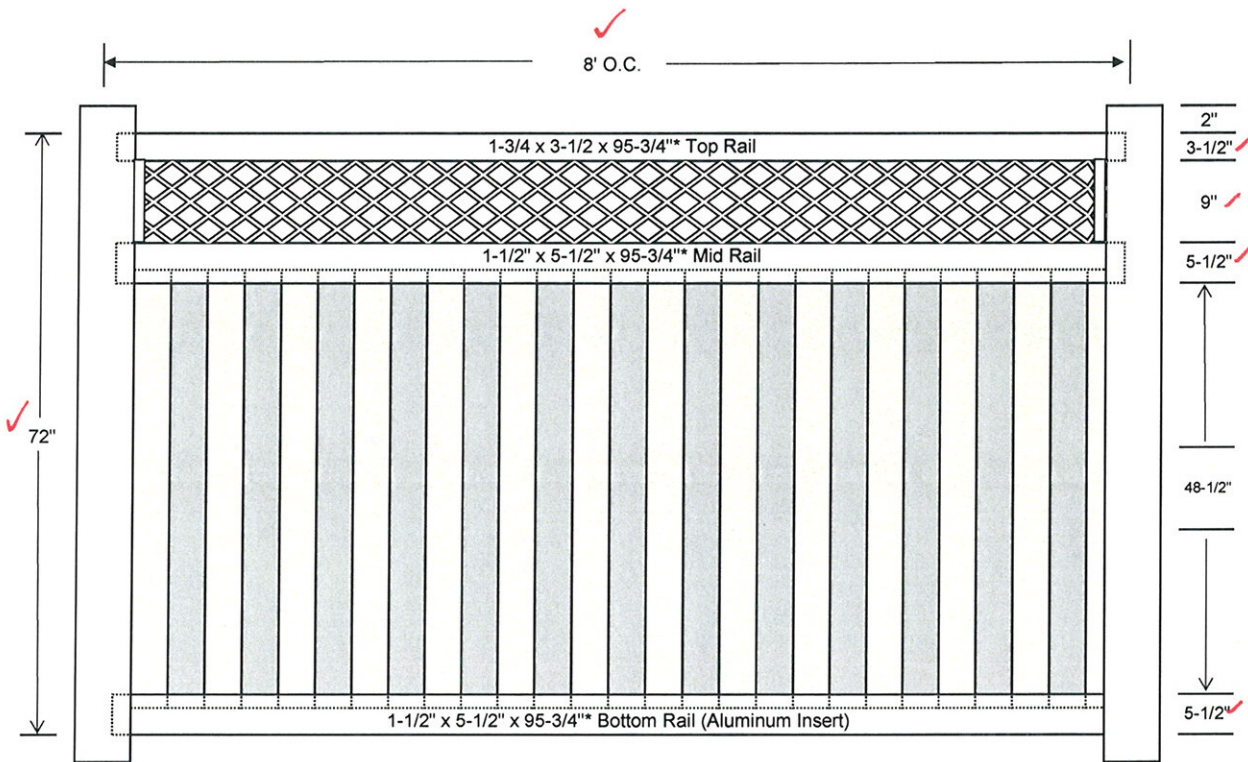

1

Material List

Qty	Item	Dimensions	WRHS USE ONLY
1	Top Rail	1-3/4" x 3-1/2" x 95-3/4"	1-3/4" x 3-1/2" x 8' Rail
1	Middle Rail	1-1/2" x 5-1/2" x 95-3/4"	1-1/2" x 5-1/2" x 8' Rail
1	Bottom Rail	1-1/2" x 5-1/2" x 95-3/4"	1-1/2" x 5-1/2" x 8' Rail
1	Aluminum Rail Insert	1-1/4" x 1-3/4" x 95-3/4"	1-1/4" x 1-3/4" x 8' Aluminum Rail Insert
1	Lattice	12" x 90.25"	16" x 90.25" Lattice
2	Lattice End Cap	7/8" x 1-1/2" x 9"	12" Lattice End Cap
7	Pickets	7/8" x 13-7/8" x 52"	7/8" X 13-7/8" X 150" Panel Privacy Picket

\*Actual measurements may vary slightly.



Architectural Testing

Test sample complies with these details.  
Deviations are noted.

Report # F9860.01-119-16

Date 7-28-16 Tech T. MICKLEY

PWPR-PANELATAH-6X8



**UltraGuard.**

**1 1/2"x5 1/2" RAIL**

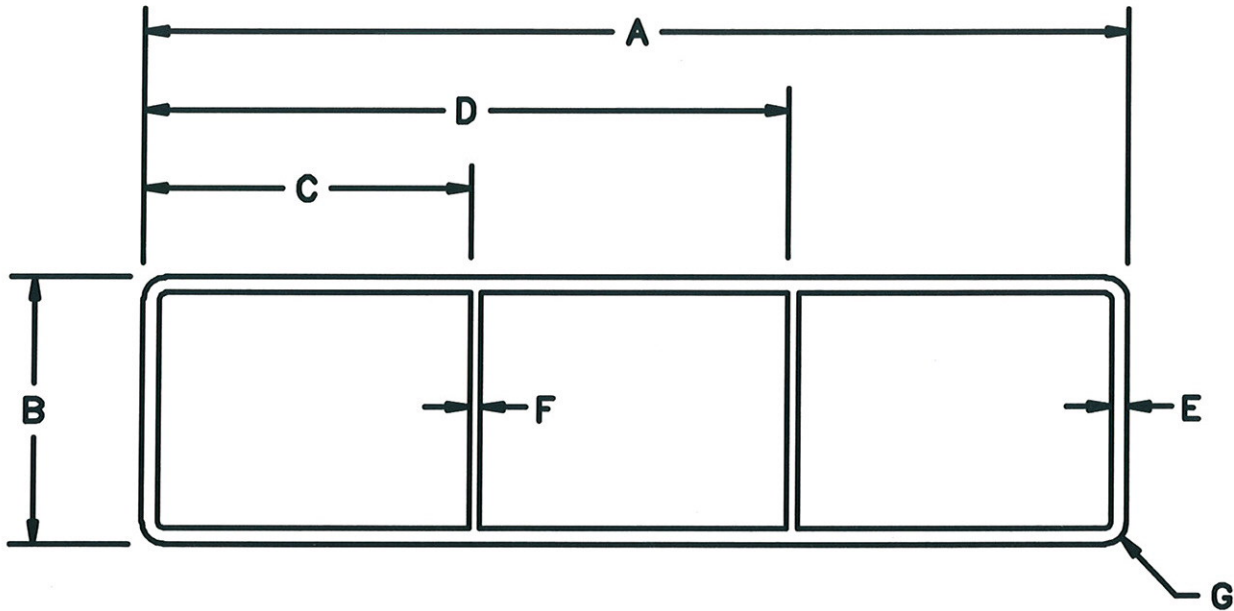

**Architectural Testing**

Test sample complies with these details.  
Deviations are noted.

Report # F9860.01-119-16

Date 7-28-16 Tech T. MICKLEY

- A. WIDTH OUTSIDE = 5.500±0.020 ✓
- B. WIDTH OUTSIDE = 1.500±0.020 ✓
- C. OUTSIDE TO FIRST RIB = 1.833 (REFERENCE) ✓
- D. OUTSIDE TO SECOND RIB = ~~3.607~~ (REFERENCE) 3.67
- E. NOMINAL WALL THICKNESS = 0.090±0.007 ✓
- F. NOMINAL RIB THICKNESS = 0.060±0.003 ✓
- G. OUTSIDE CORNER RADIUS = 0.125

WEIGHT PER FOOT - - - = 0.840 LBS.  
 OVERALL LENGTHS - - - = 6', 8', 12', 16'



**UltraGuard®**

1 3/4"x3 1/2" RAIL

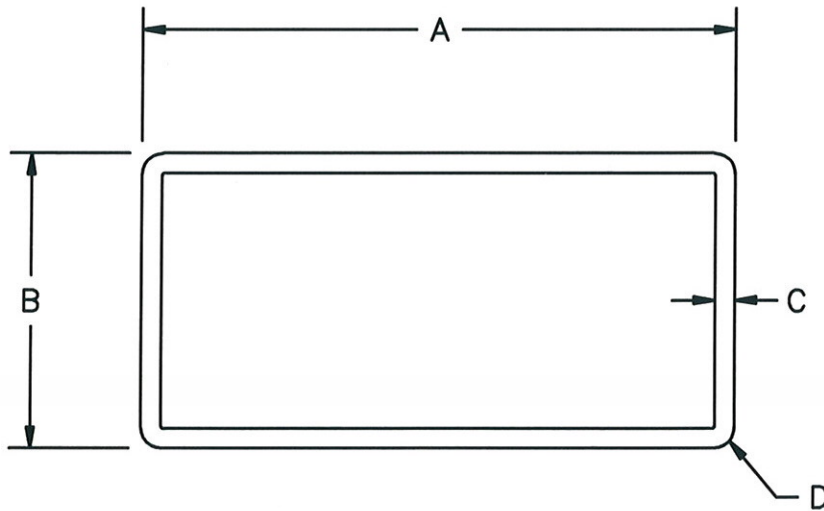

### Architectural Testing

Test sample complies with these details.  
Deviations are noted.

Report # F9860.01-119-16

Date 7-28-16 Tech T. MICKLEY

- A. WIDTH OUTSIDE =  $3.500 \pm 0.010$  ✓
- B. WIDTH OUTSIDE =  $1.750 \pm 0.007$  ✓
- C. NOMINAL WALL THICKNESS =  $0.117 \pm 0.007$  ✓
- D. OUTSIDE CORNER RADIUS = 0.125

WEIGHT PER FOOT - - - = 0.741 LBS.  
OVERALL LENGTHS - - - = 6', 12', 16'



## 14" PRIVACY PANEL

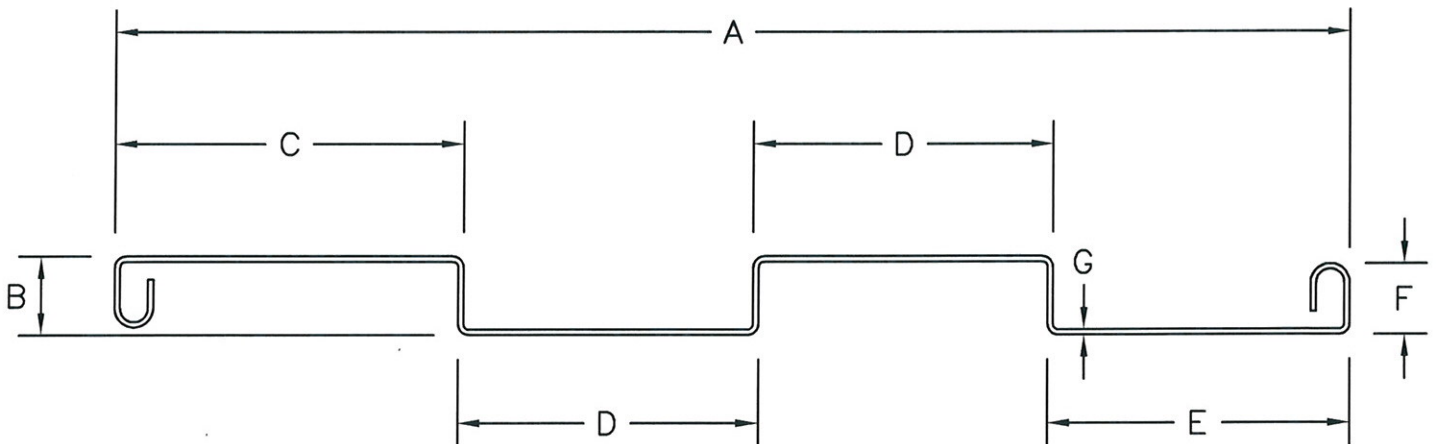

### Architectural Testing

Test sample complies with these details.  
Deviations are noted.

Report # F9860.01-119-16

Date 7-28-16 Tech T. MICKLEY

- A. OVERALL WIDTH OUTSIDE =  $13.875 \pm 0.250$  ✓
- B. WIDTH OUTSIDE =  $0.875 \pm 0.012$  ✓
- C. WIDTH OUTSIDE =  $3.920 \pm 0.010$  ✓
- D. WIDTH OUTSIDE =  $3.380 \pm 0.010$  ✓
- E. WIDTH OUTSIDE =  $3.380 \pm 0.010$  ✓
- F. LOCK HEIGHT =  $0.814 \pm 0.005$  ✓
- G. WALL THICKNESS =  $0.060 \pm 0.005$  ✓

WEIGHT PER FOOT - - - = 0.650 LBS.  
OVERALL LENGTHS - - - = 12.5' (BUNDLED)



Architectural Testing



UltraGuard®

Test sample complies with these details.  
Deviations are noted.

5" x 5" POST

Report # F9860.01-119-16

Date 7-28-16 Tech T. MICKLEY

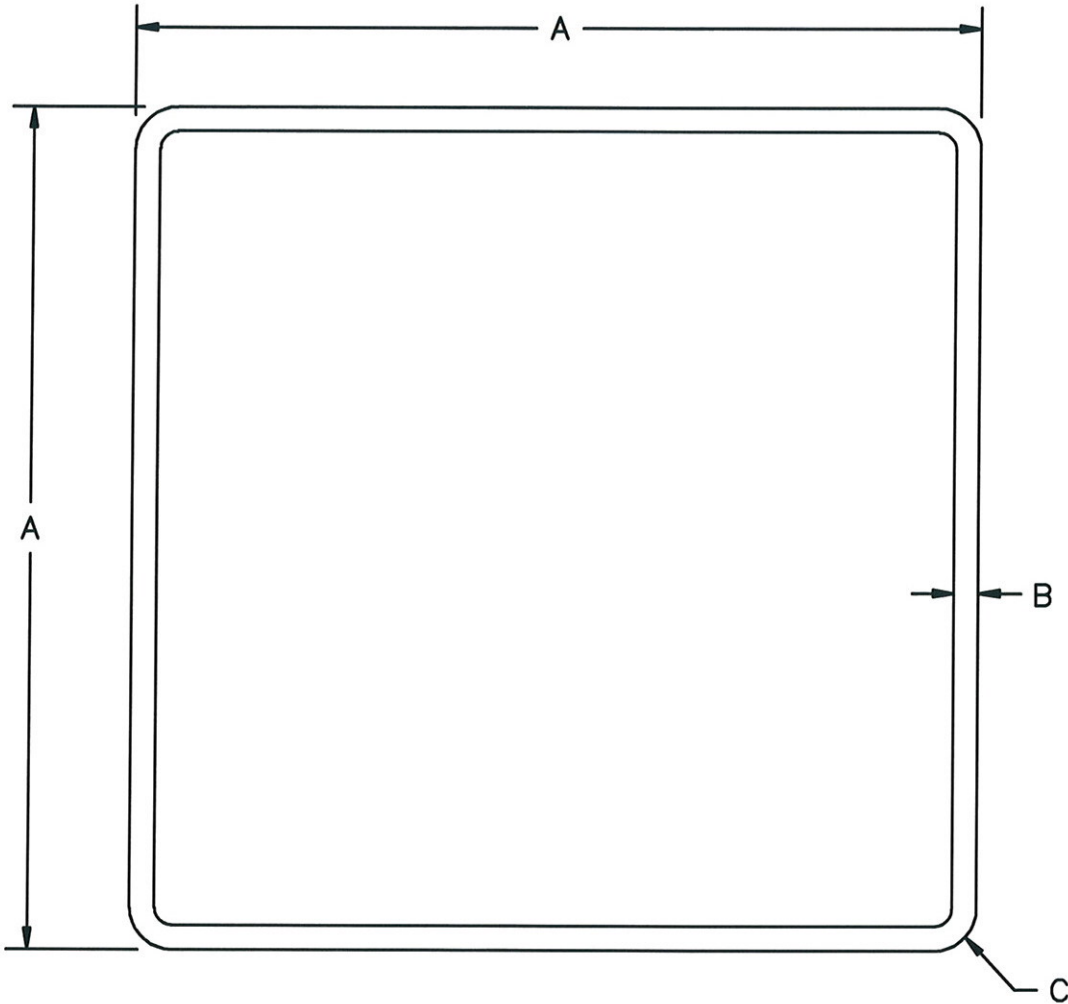

- A. WIDTH OUTSIDE =  $5.000 \pm 0.012$  ✓
- B. NOMINAL WALL THICKNESS =  $0.145 \pm 0.010$  ✓
- C. OUTSIDE CORNER RADIUS = 0.250

WEIGHT PER FOOT - - - = 1,700 LBS.

OVERALL LENGTHS - - - = 5', 6', 6.5', 7', 7.5', 8', 8.5', 9', 9.5'  
10', 12', 16'



**PRINT APPROVAL/AUTHORIZATION**

Your signature indicates your approval of the drawn extrusion cross-section as shown and dimensioned. And that you have read and accepted the foregoing. Please sign and return as soon as possible. Customer order(s) cannot proceed until print approval is received.

Approved By \_\_\_\_\_  
Customer \_\_\_\_\_  
Date \_\_\_\_\_

DRN \_\_\_\_\_ INITIAL RELEASE (NKM 12/09/02) 12079  
 DWG. RELEASE NO. \_\_\_\_\_  
 This is not an Astro design. It is Astro's interpretation of the section designed and requested by its Customer. Customer should thoroughly check the drawing and test the design before using. AS ASTRO ACCEPTS NO RESPONSIBILITY OR LIABILITY FOR THE PERFORMANCE OF GOODS OR PRODUCTS PRODUCED HEREFROM. ASTRO MAKES NO WARRANTY OF MERCHANTABILITY OR FITNESS FOR A PARTICULAR PURPOSE. WITH REGARD TO EXTRUSIONS/ PRODUCTS, PROPOSED EXPANSION TO THIS DRAWING, ASTRO'S ONLY WARRANTY SHALL BE AS STATED ON ASTRO'S SALES ACKNOWLEDGMENT FORM. ASTRO DIF. NO. \_\_\_\_\_



Test sample complies with these details.  
Deviations are noted.

Report # **F9860.01-119-16**  
 Date **7-28-16** Tech **NON T. MICKLEY**  
 EXPOSED

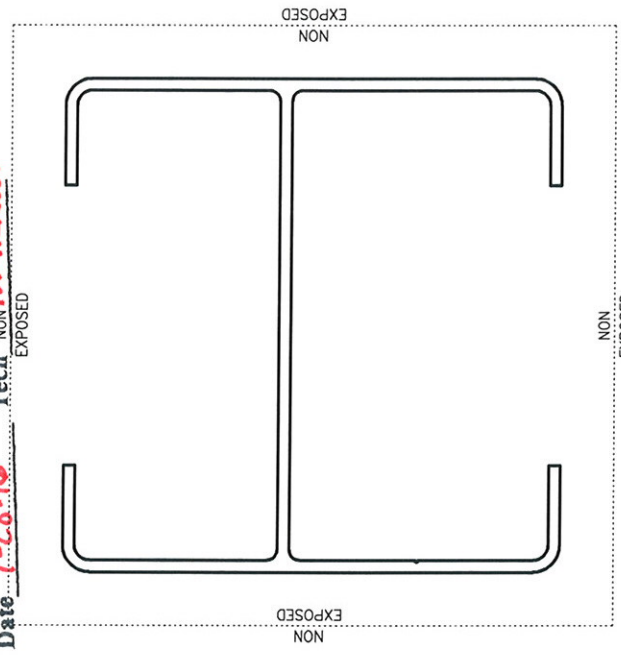

DRN	12079	ASTRO DIF. NO.	
INITIAL RELEASE	(NKM 12/09/02)		
APPROVED BY	Customer	DATE	
This is not an Astro design. It is Astro's interpretation of the section designed and requested by its Customer. Customer should thoroughly check the drawing and test the design before using. AS ASTRO ACCEPTS NO RESPONSIBILITY OR LIABILITY FOR THE PERFORMANCE OF GOODS OR PRODUCTS PRODUCED HEREFROM. ASTRO MAKES NO WARRANTY OF MERCHANTABILITY OR FITNESS FOR A PARTICULAR PURPOSE. WITH REGARD TO EXTRUSIONS/ PRODUCTS, PROPOSED EXPANSION TO THIS DRAWING, ASTRO'S ONLY WARRANTY SHALL BE AS STATED ON ASTRO'S SALES ACKNOWLEDGMENT FORM. ASTRO DIF. NO. _____			
DIM. 1.863 SQ IN S.F. 33.796 IN. O.S. PER. 6.33 IN. CR. DIA. 6.33 IN.	NET WT. 2.236 LBS. TOT. PER. 33.796 IN. FACTOR 15	CLASS. 15 TYP. WALL 0.110 ±.008	SOLID 0.000 IN. FIN. PER. 0.000 IN. TYP. WALL 0.110 ±.008
UNLESS SPECIFIED, STANDARD COMMERCIAL TOLERANCES FOR EXTRUDED ALUMINUM ARE USED.			
ASTRO ID MARK: 0.010 R X 0.010 DP			
ACTUAL SIZE MILL FINISH		ASTRO SHAPES INC. 65 MAIN ST. • STRUTHERS, OH	
(D) INDICATES 0.100 R (4) (A) INDICATES 0.140 R (4) (C) INDICATES 0.250 R (4)		DESCR 5X5 POST REINFORCEMENT CUST PART NO. _____ AS REF. NO. AS-22771	
ALL UNSPECIFIED CORNERS & FILLETS TO BE 0.015 R		SCALE 1=1 (GENLS. N.T.S.) DR. JCV DATE 12/03/02	

**PRINT APPROVAL/AUTHORIZATION**

Your signature indicates your approval of the drawn extrusion cross-section as shown and dimensioned. And that you have read and accepted the foregoing. Please sign and return as soon as possible. Customer order(s) cannot proceed until print approval is received.

Approved By \_\_\_\_\_

Customer \_\_\_\_\_

Date \_\_\_\_\_

DRN	INITIAL RELEASE (NKM 11/09/02)	12004	ASTRO DIE NO.
<small>This is not an Astro design. It is Astro's interpretation of the section designed and requested by its Customer. Customer should thoroughly check the drawing and test the design before using AS ASTRO ACCEPTS NO RESPONSIBILITY OR LIABILITY FOR THE PERFORMANCE OF GOODS OR PRODUCTS PRODUCED HEREFROM. ASTRO MAKES NO WARRANTY OF MERCHANTABILITY OR FITNESS FOR A PARTICULAR PURPOSE WITH REGARD TO EXTRUSIONS/PROFILES PRODUCED HEREFROM. ASTRO'S SOLE WARRANTY SHALL BE AS STATED ON ASTRO'S SALES ACKNOWLEDGMENT FORM.</small>			



Test sample complies with these details.  
Deviations are noted.

Report # **F9860-01-119-16**  
Date **7-28-16** Tech **T. MICKLER**

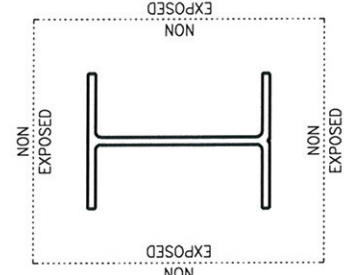
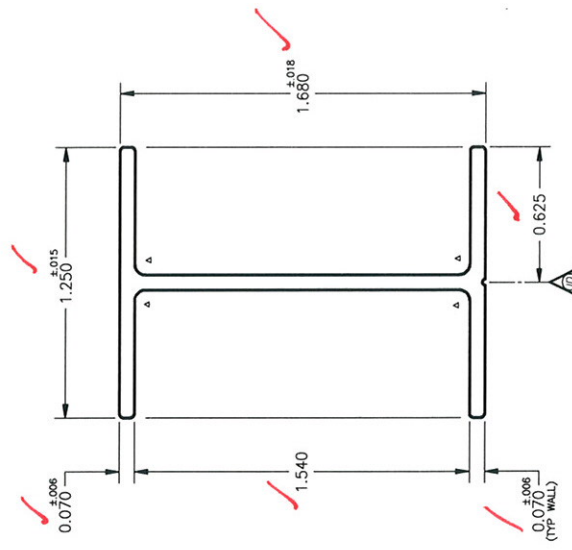

**ACTUAL SIZE**  
**MILL FINISH**

REF AREA	0.284 SQ. IN.	EST. WT./FT.	0.341 LBS.	CLASS	SOLID
CR. DIA.	8.100 IN.	EST. I/OI PER.	8.100 IN.	TYP. WALL	0.070
CR. DIA.	2.08 IN.	FACTOR	24	CUSTO	ASTRO
UNLESS SPECIFIED, STANDARD COMMERCIAL TOLERANCES FOR EXTRUDED ALUMINUM ARE USED.					
ASTRO ID MARK: 0.010 R X 0.010 DP					
ASTRO SHAPES INC. 65 MAIN ST. - STRUTHERS, OH			1.5 X 5.5 RAIL REINFORCEMENT		
CUSTO	CUST	AS REF. NO.	AS-22029	REV.	SCALE 2=1 (DETAILS N.I.S.)
				DR	ROB DATE 10/29/02

(A) INDICATES 0.050 R (4)  
ALL UNSPECIFIED CORNERS & FILLETS TO BE 0.015 R

Revision 1 10/09/03 Approval Number 0000-000

TITLE BLOCK TB0005 12/21/99





F9860.01-119-16

## **APPENDIX B**

### **Photographs**



**Photo No. 1**  
**Test Specimen in Rigid Test Fixture – Front Side**



**Photo No. 2**  
**Test Specimen in Rigid Test Fixture – Back Side**



**Photo No. 3**  
**Test Specimen During Testing**



**Photo No. 4**  
**Specimen No. 1 Failure**



**Photo No. 5**  
**Specimen No. 2 Failure**



**Photo No. 6**  
**Specimen No. 3 Failure**



**Photo No. 7**  
**Specimen No. 4 Failure**