

durables[®]

Dalton Aluminum Railing

Installation Guide

THE BEST CHOICE FOR STRONG & LASTING RAILING SYSTEMS

Our exclusive manufacturing process ensures our aluminum railing will provide superior strength plus it is virtually maintenance free. This guide will help make your installation easy. For questions, please call 1-866-719-5782 and welcome to Durables®.

Please note:

It is the responsibility of the installer to conform to local building codes and safety requirements. It is also the installer's responsibility to obtain all necessary building permits. The purchaser and installer should review the intended use of the products with a licensed professional engineer to determine code compliance. Durables® or its distributors shall not be held liable for improper or unsafe installations.

These instructions are guidelines and do not cover every installation scenario. Review all instructions before starting railing installation. The installer may need to modify the exact installation method to meet unique site requirements.

Tools:

- Hacksaw or metal cutting saw
- Drill
- Drill bits 5/32"
- Screwdriver
- Measuring tape
- Level

Step 1: Measure & Locate All Posts

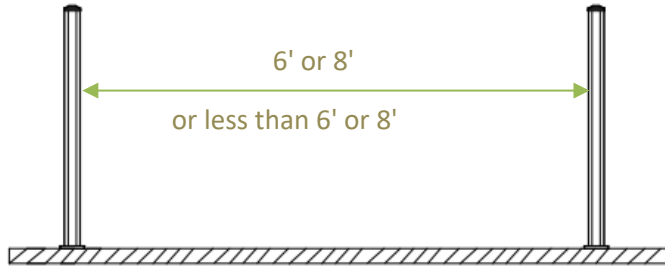

Note: The internal spacing between 2 posts is 6' and 8' or less than 6' or 8'.

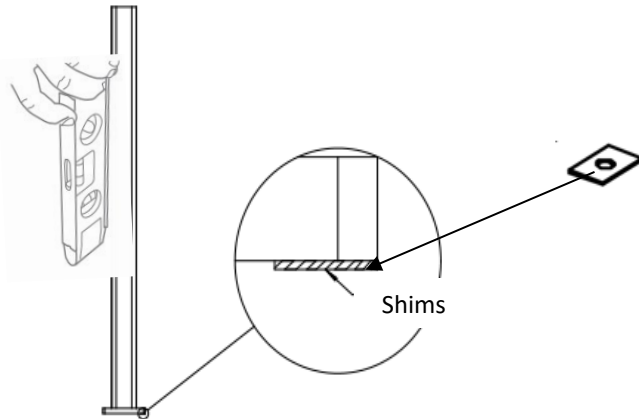

Step 2: Install bottom rail, bottom brackets and foot block(s).

1. Locate and install the foot block(s).
2. Cut bottom rail to fit between posts if necessary.
3. Secure the 3-piece adjustable foot block into place. The middle part of the foot block may be cut to adjust the height as necessary.

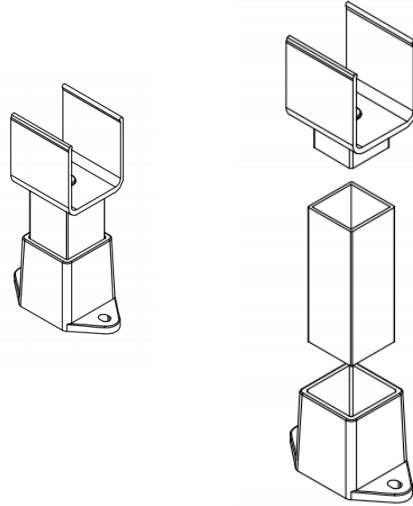

4. Insert the bottom rail into bottom bracket at both ends, then position the bottom rail between posts, secure the brackets on the post with 2 #10-1" screws.

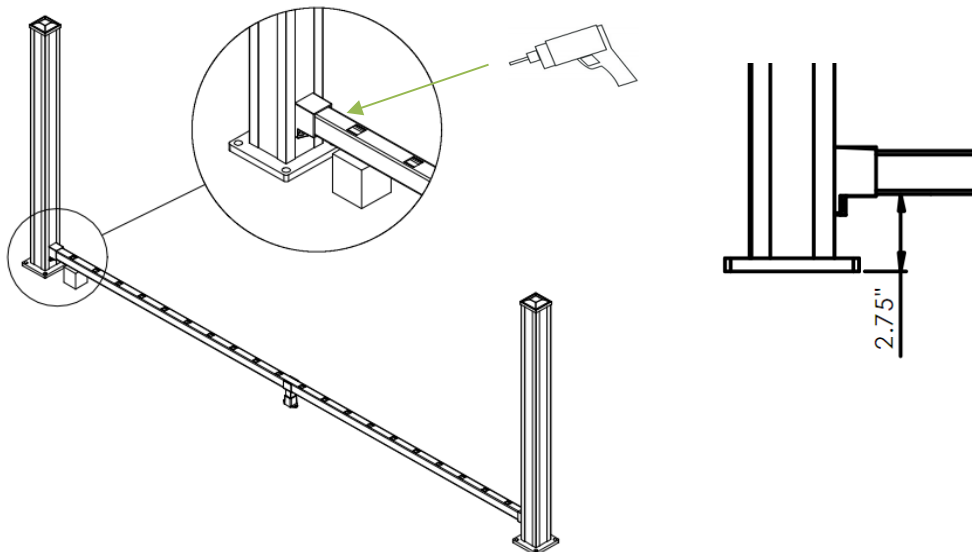

Note :

- The space between the bottom rail to the ground is 2.75", use a 2.75" high piece of wood as a temporary support.
- Pre-drill holes on the post to install the bracket.
- When cutting the bottom rail, subtract $5/16''$ from each mark and cut from both ends for even picket spacing.
- The spacer size for each rail end is different. (A special round label will be used to identify the end spacers.)
- To ensure equal picket spacing at each post use the bottom rail as a template to cut the first and last spacer.

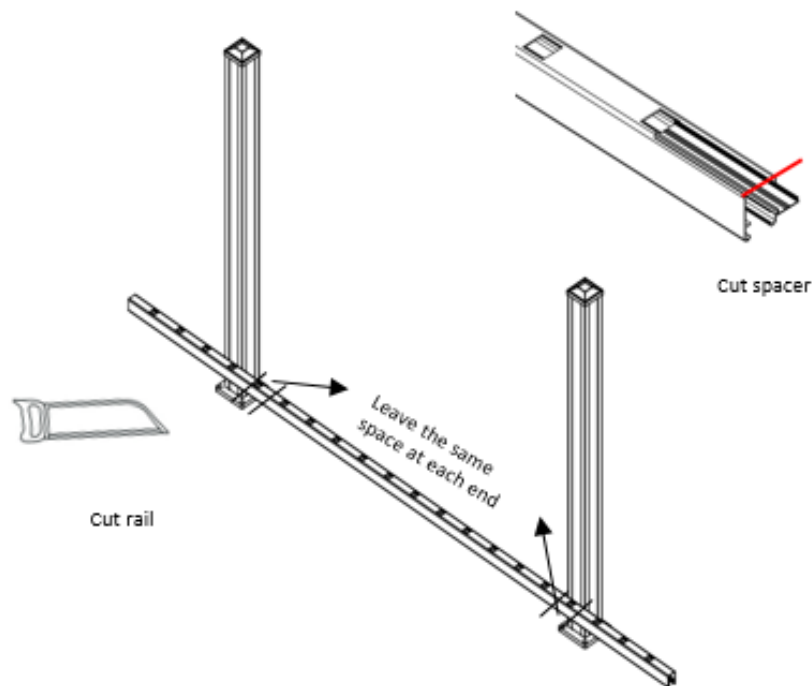

Step 3: Install top rail and top brackets.

1. Position the top bracket based on the location of the bottom bracket.

Note: The brackets should be spaced 29 1/4" apart for 36" tall railing and 35 1/4" apart for 42" tall railing.

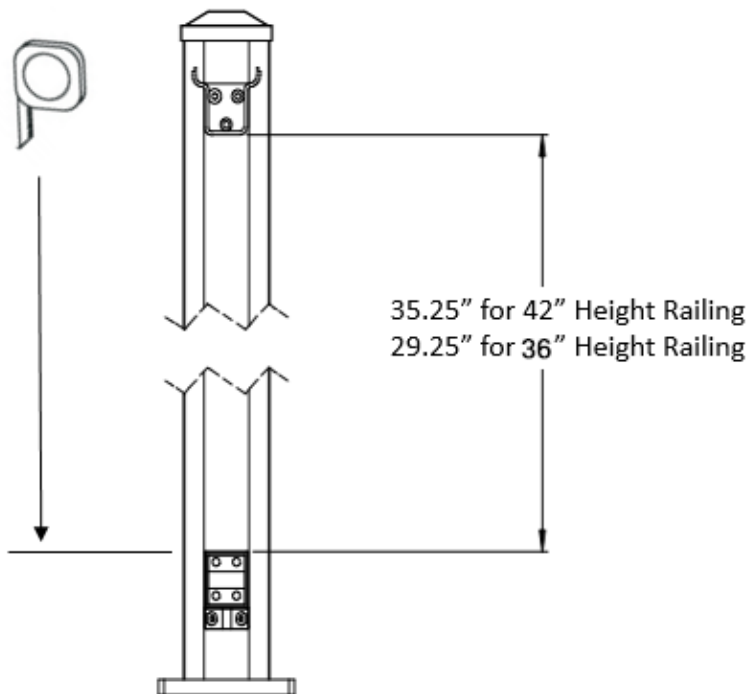

Note :
Screw the top brackets into the post using 3 #10-1" screws.

2. Measure the distance between posts and subtract 5/8 in. from the total measurement.
3. Cut the top rail at this measurement.
4. Insert the bracket cover into each end of rail. Secure the top rail with top brackets.

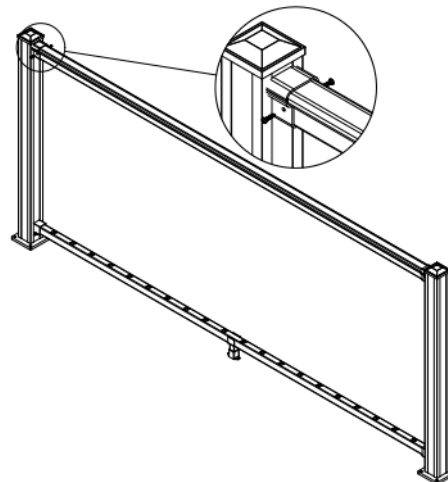
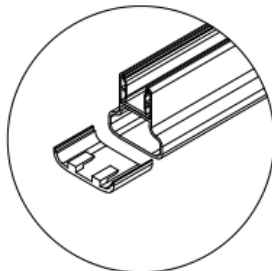

Note: Push the top rail into the bottom of top bracket. Secure top brackets to the rail using 2 #8--3/4" screws.

Step 4: Install pickets and spacers.

1. Snap the spacer into place and insert pickets into top and bottom rail one by one as shown below.

IMPORTANT: Do not snap in the last 4 spacers before installing the last 4 pickets. Insert last 4 pickets as group and adjust the picket distance, THEN snap in the spacers.

Note: The size of spacer for each rail end is different. (A special round label will be used to identify the end spacer.)

Cut spacers to fit the rails if necessary. To ensure equal picket spacing at each post, cut the first and last spacers to equal lengths.

